

S Series Filter

High Speed Routing • Sawing • Cutting
Single 'Cell' Manufacturing • After-Filters

S Series Features



Suitable for collection of many different types of dust.

850 - 8,000 m³/h

- Three phase (single phase option)
- Easy installation
- Patented Polyester Bags (99.9% efficiency)
- Quiet operation
- Bag material collection
- Collector up and running in less than 1 hour

***High Speed Routing • Sawing • Cutting
Single 'Cell' Manufacturing • After-Filters***

How It Works

...during normal operation

1. During normal operation, the dust laden air from the plant travels down the supply duct **1**
2. The dirty air then enters the **2** material handling fan
3. The dust then enters the hopper section **5** of the filter
4. As air slows down within the hopper, the heavier dust particles fall down into the inside of the collection bags **6**
5. The remaining dust then travels up into the inside of the filter bags **4**
6. The air, which originated from the plant, is now clean and passes through the filter bag into the surrounding atmosphere **3**

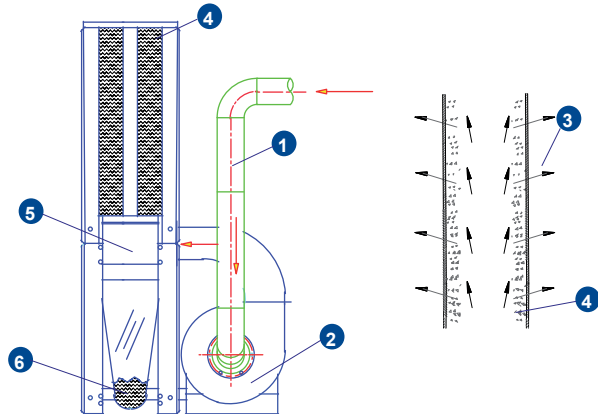

...while cleaning

1. The S Series may only clean "off-line", when the fan **2** has stopped rotating
2. The S Series is cleaned by applying physical force to the outside of the filter bag **4** which, in effect, shakes them
3. The dust cake, which hangs on the inside of the filter bag, falls into the hopper section and then into the collection bags below **6**

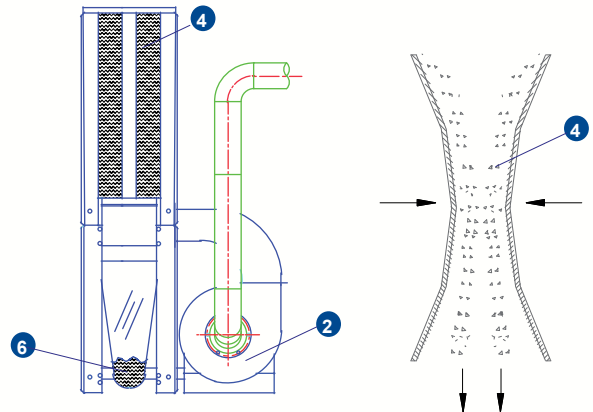

S Series

Bag Filter

S - 200

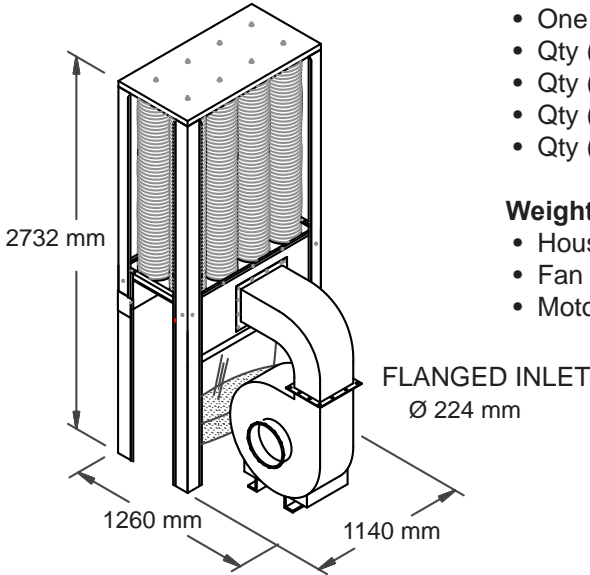

Basic Model Features

- 7.5 m² of filter media
- One waste discharge point
- Qty (1) 2.2kW (2.5 Hp), 3000 RPM, motor
- Qty (8) filter bags
- Qty (1) plastic waste collection bag
- Qty (1) clamps for easy removal of waste bag

Weight

- Housing 82 kg.
- Fan 56 kg.
- Motor 14 kg.

Model Number Selection:

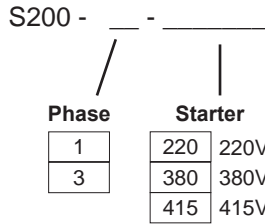

Capacity			
Static pressure	165mm Wg	146mm Wg	117mm Wg
Air volume	1700 m ³ /h	2600 m ³ /h	3400 m ³ /h
Air volume	1000 ft ³ /min	1530 ft ³ /min	2000 ft ³ /min

S - 500

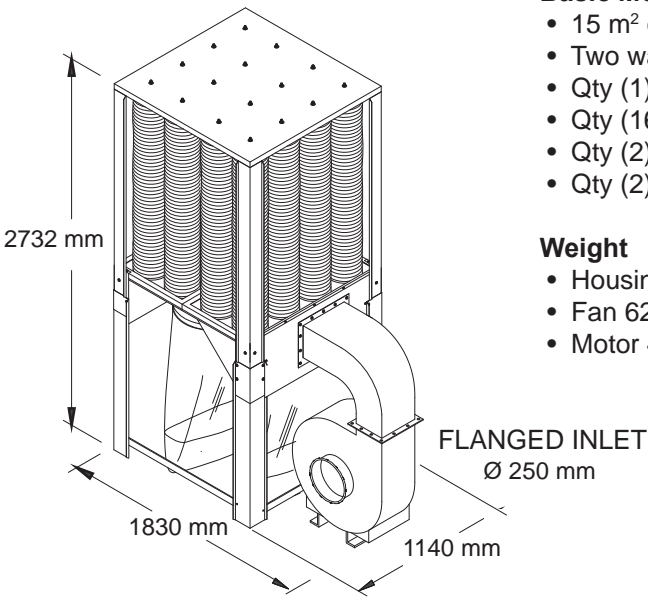

Basic Model Features

- 15 m² of filter media
- Two waste discharge points
- Qty (1) 4.0kW (5 Hp), 3000 RPM, motor
- Qty (16) filter bags
- Qty (2) plastic waste collection bag
- Qty (2) clamps for easy removal of waste bags

Weight

- Housing 120 kg.
- Fan 62 kg.
- Motor 45 kg.

Model Number Selection:

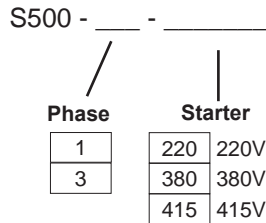

Capacity			
Static pressure	203mm Wg	190mm Wg	127mm Wg
Air volume	2600 m ³ /h	3400 m ³ /h	5000 m ³ /h
Air volume	1530 ft ³ /min	2000 ft ³ /min	2941 ft ³ /min

S - 750

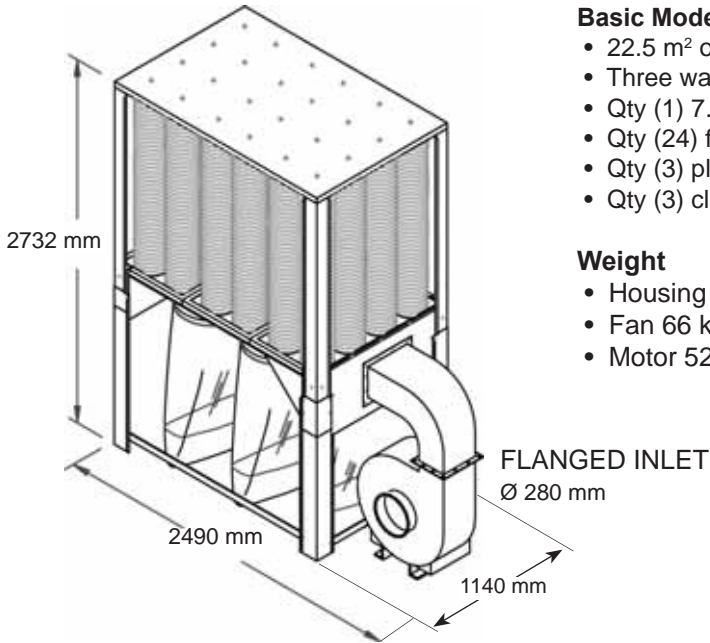

Basic Model Features

- 22.5 m² of filter media
- Three waste discharge points
- Qty (1) 7.5kW (10 Hp), 3000 RPM, motor
- Qty (24) filter bags
- Qty (3) plastic waste collection bag
- Qty (3) clamps for easy removal of waste bags

Weight

- Housing 146 kg.
- Fan 66 kg.
- Motor 52 kg.

Model Number Selection:

S750 - - -

Phase	Starter	
1	220	220V
3	380	380V
	415	415V

Capacity			
Static pressure	254mm Wg	203mm Wg	152mm Wg
Air volume	4250 m ³ /h	6000 m ³ /h	8000 m ³ /h
Air volume	2500 ft ³ /min	3530 ft ³ /min	4705 ft ³ /min

Compulsories

Fan inlet adapter to QF Ducting



Standard inlet: Ø 224, Ø 250, Ø 280

Accessories

Ducting Kit for CNC router



QF Ducting System, Flexible Hose 6 M.



Controller only



Controller with 3 M. cabel



Filter Bag



Plastic Bag



Wheel Support

S Series

How to select

How to select S-series filter

(How many machines can be connected to a certain s-series filter?)

Airflow of the machine(s) can be determine by below figure

m³/h in different duct sizes at different air speeds

Ø	20 m/s	25 m/s	28 m/s	32 m/s
100 mm	565	707	792	905
125 mm	884	1104	1237	1414
140 mm	1108	1385	1552	1773
160 mm	1448	1809	2027	2316
180 mm	1832	2290	2526	2931
200 mm	2262	2827	3167	3619
250 mm	3534	4418	4948	5655
315 mm	5611	7013	7855	8977
350 mm	6927	8658	9697	11083

Example:

Two machines, where router machine has one extraction points of Ø100 mm and saw has one extraction point of Ø200 both needs an air speed of 25 m/s.

This will result in the following calculation.

Machine nr	# of suction hoods	Ø	m/s	m ³ /h
Router	1	100	25	707
Saw	1	200	25	2827

S-series filter selection depended on pressure drop of the machine(s), ducting and flexible hose.

Pressure drop guideline

- Open Machine: (Cutting saw, drilling) 10-50 mmWg
- Semi-Open Machine: (Table saw, Double-end, edge bander) 50-100 mmWg
- Close-Machine: (CNC, Wide belt sander) 100-200 mmWg
- Hood and Flexible Hose: 50-100mmWg

S-200			
Pressure drop (mmWg)	165	146	117
Air volume (m ³ /h)	1700	2600	3400

S-500			
Pressure drop (mmWg)	203	190	127
Air volume (m ³ /h)	2600	3400	5000

S-750			
Pressure drop (mmWg)	254	203	152
Air volume (m ³ /h)	4250	6000	8000

S Series installation





FACTS ABOUT NEDERMAN

The Nederman Group is one of the world's leading suppliers of products and solutions within the environmental technology sector, focusing on industrial air filtration and recycling.

Nederman products and solutions contribute to reducing environmental impacts from industrial production and to creating safe and clean working environments whilst boosting production efficiency.

The group's offering covers everything from the design stage through to installation, commissioning and servicing. Nederman has subsidiaries in 29 countries and agents and distributors in over 30 countries.

Nederman is ISO 9001 and 14001 certified. The group develops and produces in its own manufacturing and assembly units in Europe, North America and Asia.

In 2010 Nederman acquired Dantherm Filtration, thereby forming the world's leading group within industrial air filtration.

Nederman

www.nederman.com

Nederman S.E.A. Co., Ltd.

66/1 Moo 11 Bangkruay-Sainoi Road, T. Bangbuathong, A. Bangbuathong, Nonthaburi 11110, Thailand.

Phone: +66 2715 1300 Fax: +66 2715 1301 Email: info.th@nederman.com

Vietnam Representative Office in Ho Chi Minh City: Phone: +84 835 265 541 Fax: +84 835 265 541 Email: info.vn@nederman.com

Nederman (Malaysia) Sdn. Bhd. (892768-T): Phone: +603 8940 1192 Fax: +603 8940 1196 Email: info.my@nederman.com

Indonesia Representative Office: Phone: +62 815 1499 7996 Fax: +62 815 1499 7996 Email: info.id@nederman.com

Nederman Sales companies in: Australia, Austria, Belgium, Brazil, Canada, China, Czech Rep. Denmark, France, Germany, Hungary, India, Ireland, Malaysia, Northern Ireland, Norway, Poland, Portugal, Romania, Russia, Slovak Republic, Spain, Sweden, Thailand, Turkey, United Kingdom, USA, Vietnam

Nederman Agents in: Bulgaria, Cyprus, Egypt, Estonia, Finland, Greece, Holland, Hongkong, Iceland, Iran, Ireland, Italy, Japan, Korea, Latvia, Lithuania, Malaysia, New Zealand, Philippines, Saudi Arabia, Serbia, Singapore, Slovenia, South Africa, Switzerland, Taiwan R.O.C, Thailand, Turkey, United Arab Emirates